

PRELIMINARY SOLUTION OF TRAFFIC SURFACES WITHIN THE PARCEL OF THE FACULTY OF CIVIL ENGINEERING IN SUBOTICA

IDEJNO REŠENJE SAOBRAĆAJNIH POVRŠINA U OKVIRU PARCELE GRAĐEVINSKOG FAKULTETA U SUBOTICI

Jovan Škondrić¹
Igor Jokanović²

UDK: 625.712.25
DOI: 10.14415/zbornikGFS32.006
CC-BY-SA 4.0 license

Summary: Extension of the capacities of the Faculty of Civil Engineering building in Subotica in the form of annexes and sports hall (second phase) requires an adequate traffic infrastructure that would satisfy the additional demands. The paper presents the possible solution of traffic surfaces that service the entire lot, as well as the landscaping on the free part of the lot.

Keywords: traffic areas, parking lots, landscaping, pedestrian lanes

Rezime: Proširenje kapaciteta Građevinskog fakulteta Subotica u vidu aneksa i sportske hale (druga faza) zahteva i odgovarajuću saobraćajnu infrastrukturu koja bi zadovoljila dopunsku potražnju. U radu je prikazano moguće rešenje saobraćajnih površina koje servisira kompletnu parcelu, kao i uređenje zelenih površina na slobodnom delu parcele.

Ključne reči: saobraćajne površine, parking mesta, obrada zelenih površina, pešačke staze

1. INTRODUCTION

As part of the project of the extension of capacities at the Faculty of Civil Engineering in Subotica, the construction of an annex of the main building was planned, which would contain additional classrooms, offices, halls, a new canteen, as well as a new laboratory for testing construction materials. The new building would be located laterally, in the continuation of the existing Faculty building (on the left side) and connected by a warm passageway, that would be located above the side road (Figure 1). The existing laboratory shall be relocated to the basement of the new building. Due to the planned construction of the

1. UVOD

U okviru projekta proširenja kapaciteta Građevinskog fakulteta Subotica planirana je izgradnja aneksa glavnog objekta koji bi sadržao dodatne učionice, kancelarije, sale, novu kantinu, kao i novu laboratoriju za ispitivanje građevinskog materijala. Nova zgrada bi bila locirana bočno u nastavku postojeće zgrade fakulteta (sa leve strane) i spojena toplom vezom, hodnicima koji bi se nalazili iznad bočne saobraćajnice (Slika 1). Postojeća laboratorija bi trebalo da bude premeštena u suteren nove zgrade.

Zbog planirane izgradnje aneksa objekta, kao i sportske hale u drugoj

¹ Jovan Škondrić, Civil Eng. Belgrade, Serbia, e-mail: skondric.jovan@gmail.com

² Prof. Igor Jokanović, Ph.D., Grad. Civil Eng., University of Novi Sad, Faculty of Civil Engineering Subotica, 2a Kozaračka Str., Subotica, Serbia, e-mail: jokanovici@gf.uns.ac.rs

annex of the building, as well as the sports hall in the second phase, in addition to the existing building of the faculty, preparation of preliminary solution of traffic surfaces started, including the processing of the entire traffic surfaces, consisting of vehicles and pedestrian areas, parking lots and green areas (pedestrian lanes) on the lot where the Faculty building is situated, in Kozaracka street no. 2a, in Subotica, Cadastral Municipality Stari Grad, lot number 19643, Real Estate Folio in the Land Register 1006, number of plan 28. Total surface of the lot is 21,723 m².

fazi, pored postojeće zgrade fakulteta, pristupilo se izradi idejnog rešenja saobraćajnih površina kojim je obuhvaćena obrada svih saobraćajnih površina, koje se sastoje od kolsko-pešačkih površina, parking mesta i zelenih površina (pešačkih staze) na parceli fakulteta, u Kozaračkoj ulici br. 2a, u Subotici, K.O. Stari Grad, broj parcele 19643, broj lista nepokretnosti 1006, broj plana 28. Ukupna površina parcele iznosi 21.723 m².

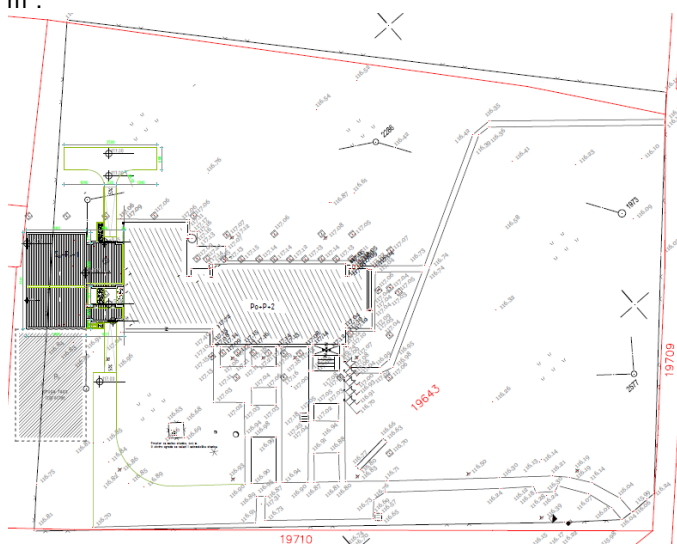

Slika 1 - Postojeće stanje sa planiranim proširenjem zgrade
Figure 1 - Current condition with planned extension of building

2. EXISTING CONDITION

The subject lot, in the existing condition (Figure 1) contains road and parking lots in front of the building, with asphalt finishing in the total length of about 00 m. During some working days, as well as in the event of seminars and conferences held at the Faculty, parking space capacities are fully used up, and as consequence, some vehicles are parked at the green areas. When delivering the samples and

2. POSTOJEĆE STANJE

Na predmetnoj parceli se u postojećem stanju (Slika 1) nalazi saobraćajnica i parking mesta sa prednje strane zgrade, i to sa završnom obradom od asfalta u ukupnoj dužini od oko 200 m. U toku pojedinih radnih dana, kao i prilikom održavanja seminara i konferencija na fakultetu dolazi do potpunog iskorišćenja kapaciteta za parkiranje, te se vozila parkiraju i na zelenim površinama. Prilikom dostave

materials to the laboratory for testing the construction materials, manoeuvre of delivery vehicles is difficult due to insufficient space. The same problem occurs with communal vehicles when picking up the containers for bulk waste and/or emptying the containers for communal waste. The existing pedestrian lane that connects Faculty building with Dudova šuma was made of 40 x 40 cm concrete blocks, and it is 160 cm wide. Along with pedestrian lane there is not any rest area for students and visitors of the Faculty, such as benches, which can be evaluated as significant shortage of the existing plateau arrangement of the lot where faculty is situated.

3. TRAFFIC SOLUTION

Construction of new traffic road, that circles around the Faculty area, assumes two branches of the same (Figure 2). One branch goes right and behind the existing building of the Faculty; it is 4,00 m wide and 225,00 m long in total, and ends at the designed terminus. In front of and left from the Faculty building the reconstruction of the existing access is envisaged. The new traffic route continues the axis of the existing one and goes from the side of the building to bus terminus at the northern corner of the lot. At the position of the terminus, the area is connected with the traffic route that goes around the lot. After the envisaged sports hall, the traffic route shall decline to the depth of 0.67 m, to reach the elevation of 116.33 m, in front of the side entrance to the laboratory (Figure 3). Lowering the level was performed by the 15.00 m long ramp, with 4.5% slope angle. Curvature of the final level section has not been carried out due to relatively small slope of ramps, as well as small section angle. Ramps are secured by construction of reinforced concrete walls, with minimum thickness of 20 cm. Length of

uzoraka i materijala u laboratoriju za ispitivanje građevinskih materijala dolazi do otežanog manevrisanja dostavnih vozila zbog nedovoljnog prostora za obavljanje istog. Isti problem se pojavljuje i prilikom dolaska komunalnog vozila za odnošenje kontejnera za kabasti otpad i/ili pražnjenje kontejnera za komunalni otpad. Postojeća pešačka staza koja povezuje zgradu fakulteta sa Dudovom šumom je urađena od betonskih blokova dimenzija 40 x 40 cm, i to u širini od 160 cm. Uz pešačku stazu ne postoji mesto za odmor studenata i posetilaca fakulteta, kao što su npr. klupe za sedenje i to se može oceniti kao značajan nedostatak postojećeg parternog uređenja parcele na kojoj se nalazi fakultet.

3. SAOBRAĆAJNO REŠENJE

Izgradnja nove, praktično kružne saobraćajnice oko parcele fakulteta, podrazumeva dva kraka iste (Slika 2). Jedan krak se pruža desno i iza postojeće zgrade fakulteta; širine je 4,00 m i ukupne dužine 225,00 m, do projektovane okretnice. Ispred i levo od zgrade fakulteta, je predviđena rekonstrukcija postojećeg prilaza. Saobraćajnica se osovinski nadovezuje na postojeću i pruža se sa bočne strane zgrade do okretnice koja se nalazi u severnom uglu parcele. Na poziciji okretnice se ovaj kraj spaja sa saobraćajnicom koja se pruža oko parcele. Saobraćajnica se na delu nakon predviđene sportske hale ukopava na dubinu od 0,67 m, do visinske kote 116,33 m ispred bočnog ulaza u laboratoriju (Slika 3). Spuštanje nivelete je obavljeno rampom dužine 15,00 m, u nagibu 4,5%. Zaobljenje preloma nivelete nije rađeno zbog relativno malog nagiba samih rampi, kao i malog prelomnog ugla. Rampe su osigurane izradom potpornih armirano-betonskih zidova, minimalne debljine 20 cm. Dužina ukopane saobraćajnice je

the declined traffic route is 21.63 m. Finishing of ramps was carried out in the same manner as for the other traffic surfaces within the complex, by using Behaton elements. Over the finishing layer, i.e. on the Behaton elements, the standard concrete curbs 20/24 cm, 100 cm long were placed at the layer of lean concrete MB15, minimum 15 cm thick, in continuity along the edge of the supporting walls, to avoid collision or abrasion of vehicles along the wall. Hence, the safety curbs were designed at the level of the finishing layer of the ramp, to avoid inclining the wheel of the vehicle on the curb. Securing the ramp from the upper sides is provided through the gardeners. The total length of the circular road is 489.09 m.

21,63 m. Završna obrada rampi je obavljena kao i za ostale saobraćajne površine u kompleksu, upotrebom Behaton elemenata. Na završnu obradu, odnosno Behaton element, ugrađeni su standardni betonski ivičnjaci 20/24 cm, dužine 100 cm na sloju mršavog betona MB15, minimalne debljine 15 cm, u kontinuitetu uz samu ivicu potpornih zidova, kako ne bi došlo do udara ili struganja vozila o zid. U tom smislu su predviđeni i zaštitni ivičnjaci na visini završne obrade rampe, kako ne bi došlo do penjanja točka vozila na ivičnjak. Obezbeđenje rampe sa gornjih strana je predviđeno putem žardinjera. Ukupna dužina kružne saobraćajnice iznosi 489,09 m.

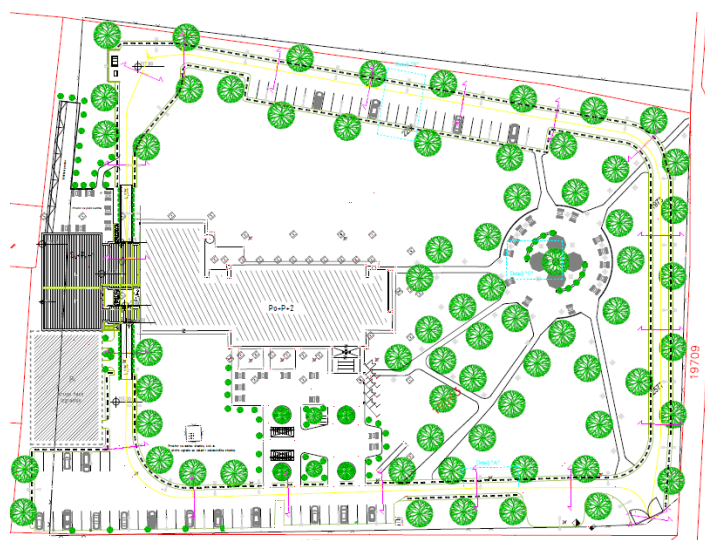

Slika 2 - Uređenje saobraćajnih i zelenih površina, varijanta I
Figure 2 - Arrangement of traffic surfaces and landscaping, option I

Terminus

When designing the terminus behind the Faculty, in the northern corner of the plot, a special terminus was adopted without additional manoeuvring of the vehicle, type A, with a radius of 8.00 m which can service all types of vehicles. The waste containers are located at the corner of the terminus.

Okretnica

Prilikom projektovanja okretnice iza fakulteta, u severnom uglu parcele, usvojena je specijalna okretnica bez dodatnog manevrisanja vozila, tip A, radijusa 8,00 m koja može servisirati sve tipove vozila. U uglu okretnice je pozicija za lociranje otpadnih kontejnera. Pozicija kontejnera sa

Position of the containers on the back and at the sides is enclosed by construction of the wall made of reinforced concrete, 120 cm high and 20 cm thick.

zadnje i sa bočnih strana je ograđena izradom armirano-betonskog zida, visine 120 cm i debljine 20 cm.

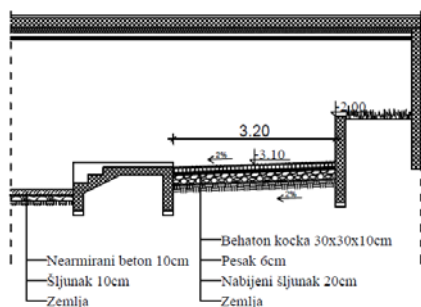

Slika 3 - Bočni prilaz ispod tople veze
Figure 3 - Side access under warm passageway

Parking areas

Existing parking lots are maintained, with the reconstruction of the surface and drainage system (Figure 4).

After the completion of the construction of the sports hall and during the organization of various seminars and conferences held in the faculty building, it is estimated that there will be a large increase in people's visits, and therefore vehicles, and new parking spaces are foreseen in the continuation of existing until the sports hall (second expansion phase), and with a new roadway that runs around the lot, or behind the faculty. The model of perpendicular parking is applied, and the dimensions of parking spaces are 5,00 m x 2,50 m. In front of the faculty, all the way to the sports hall, 43 parking lots were designed, as well as 30 parking lots along the road running behind the faculty. A total number of 73 parking lots are foreseen.

Final treatment of traffic surfaces

Levelling the elevations of the road and other surfaces are achieved by mechanical excavation to the design required depths, and the stability and

Parking površine

Postojeći parkinzi su zadržani uz rekonstrukciju površine i sistema za odvodnjavanje (Slika 4).

Nakon završetka izgradnje sportske hale i prilikom organizovanja raznih seminara i konferencija koje se održavaju u zgradi fakulteta, procenjeno je da će doći do velikog povećanja posete ljudi, a samim tim i vozila, te su predviđena nova parking mesta u nastavku postojećih do sportske hale (druga faza proširenja), i uz novu saobraćajnicu koja se pruža oko parcele, odnosno iza fakulteta. Primenjen je model upravnog parkiranja, a dimenzije parking mesta su 5,00 m x 2,50 m. Projektovano je 43 parking mesta ispred fakulteta do sportske hale kao i 30 parking mesta uz saobraćajnicu koja se pruža iza fakulteta. Ukupno je predviđeno 73 parking mesta.

Završna obrada saobraćajnih površina

Nivelacione kote saobraćajnice i drugih površina se postižu mehaničkim iskopom do potrebne dubine predvi-

bearing capacity are ensured by mechanical compacting of the base. Then the layers of gravel and sand are placed, in the appropriate thickness and mechanically compacted to achieve the required bearing capacity and quality. Beton elements are placed on the compacted layer of sand, as follows:

- on the traffic roads - Beton cubes, 30 x 30 x 10 cm (Figure 5);
- on the roadsides - honeycomb shaped Beton blocks 30 x 30 x 10 cm (Figure 5);
- on pedestrian lanes - honeycomb shaped Beton blocks 30 x 30 x 10 cm (Figure 5);
- on the separation lines on the parking lots - Beton blocks 40 x 20 x 10 cm.

đene projektom, a stabilnost i nosivost se osiguravaju mehaničkim zbijanjem podloge. Potom se nasipaju slojevi šljunka i peska, u odgovarajućoj debljini i mehanički zbijaju radi postizanja zahtevane nosivosti i kvaliteta. Na zbijeni sloj peska se postavljaju beton elementi, i to:

- na saobraćajnicama - Beton kocke, 30 x 30 x 10 cm (Slika 5);
- na ivičnom pojasu - Beton saće 30 x 30 x 10 cm (Slika 5);
- na pešačkim stazama - Beton saće 30 x 30 x 10 cm (Slika 5);
- na razdelnim trakama na parkinzima - Beton blok 40 x 20 x 10 cm.

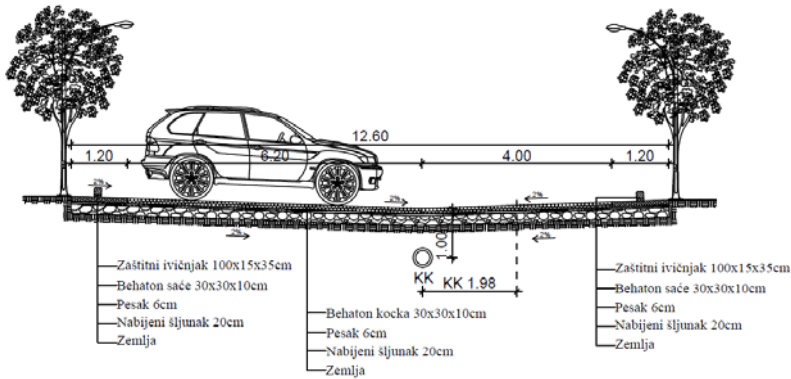

Slika 4 - Rekonstrukcija postojećeg parking prostora
Figure 4 - Reconstruction of the existing parking area

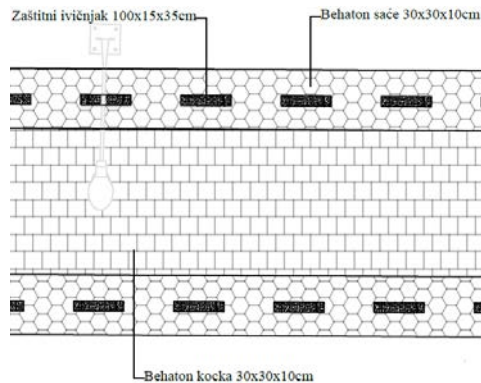

Slika 5 - Završna obrada saobraćajnih površina
Figure 5 - Final treatment of traffic surfaces

Protection of green areas

Protection curbs are designed to protect cars from parking on the green surface (Figure 6). The protection curb is placed on both roadsides at a distance of 50 cm from the edge of the run-off carriageway, thus physically preventing the access and parking of vehicles on a green surface and on pedestrian lanes. The width of the protective zone is 120 cm on each side of the road. The curbs are placed on a layer of lean concrete MB15, minimum thickness 15 cm, with a distance of 100 cm between the two curbs. During the placement, the curb should be buried 15 cm below the surface of the roadside. The dimensions of the protective curbs are 100 x 15 x 35 cm with edges inclined at an angle of 45°.

Zaštita zelenih površina

Radi zaštite od parkiranja vozila na zelenu površinu predviđeni su zaštitni ivičnjaci (Slika 6). Zaštitni ivičnjak je postavljen u ivičnom pojasu sa obe strane saobraćajnice na udaljenosti od 50 cm od ivice protočnog kolovoza i time je fizički onemogućen prilazak i parkiranje vozila na zelenu površinu i na pešačke staze. Širina zaštitnog pojasa je 120 cm sa obe strane saobraćajnice. Ivičnjak je postavljen na sloju mršavog betona MB15, minimalne debljine 15 cm, sa rastojanjem od 100 cm između dva ivičnjaka. Prilikom ugrađivanja, ivičnjak treba ukopati 15 cm ispod površine ivičnog pojasa. Dimenzije zaštitnog ivičnjaka su 100 x 15 x 35 cm sa ivicama zakošenim pod uglom od 45°.

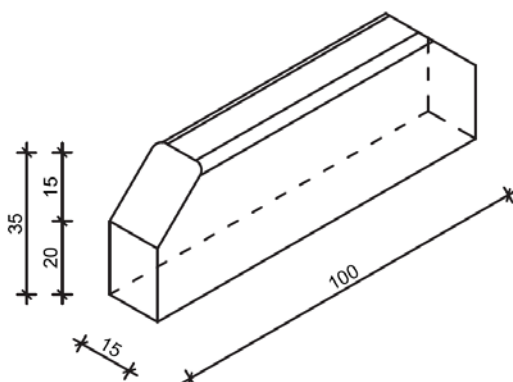

Slika 6 - Zaštitni ivičnjak
Figure 6 - Protection curb

Vegetation around traffic surfaces

The vegetation around the traffic lights and parking spaces, shall consist of plane trees. Plane trees are fast-growing trees with maximum heights of up to 35 m, ideal for covering traffic surfaces. They provide adequate shade and fit well with other tree species. They are favoured in urban areas. It is noted that during the work out of main design, the existing plant stock on the lot should be completely

Vegetacija oko saobraćajnih površina

Kao vegetacija oko saobraćajnica i parking mesta predviđeni su platani. Platani spadaju u brzorastuće drveće, maksimalne visine do 35 m, idealne za pokrivanje saobraćajnih površina. Pružaju odgovarajući hlad i dobro se uklapaju sa drugim vrstama drveća. Omiljeni su u urbanim sredinama. Napominje se da prilikom izrade glavnog projekta treba u potpunosti

established, and the final design of the landscaping will be carried out accordingly.

Additional content

The new canteen space (Figure 7) is located within the annex with an outer plateau for the garden, around 150 m². There are also places for sitting and resting (benches) on the plateau. The pedestrian lane leads from the plateau across the road to the container location, for the disposal of waste.

In addition to the canteen plateau, there is also an exhibition space (Figure 7), dimensions 35 x 5.5 m with a canopy, intended for exhibiting models and results of projects and testing during the preparation of doctoral dissertations, both former and future Ph.D. students.

utvrditi biljni fond na parceli, te u skladu sa tim izvršiti konačno projektovanje uređenja zelenilom.

Dodatni sadržaji

Novi prostor kantine (Slika 7) se nalazi u sklopu aneksa sa spoljašnjim platoom za baštu, površine oko 150 m². Na platou su postavljena i mesta za sedenje i odmor (klupe). Pešačka staza vodi od platoa preko saobraćajnice do mesta za kontejnere, radi odlaganja otpada.

Pored platoa za kantinu je predviđen i izložbeni prostor (Slika 7), dimenzija 35 x 5,5 m sa nadstrešnicom, namenjen za izlaganje modela i rezultata projekata i ispitivanja prilikom izrade doktorskih disertacija, kako bivših tako i budućih studenata doktorskih studija.

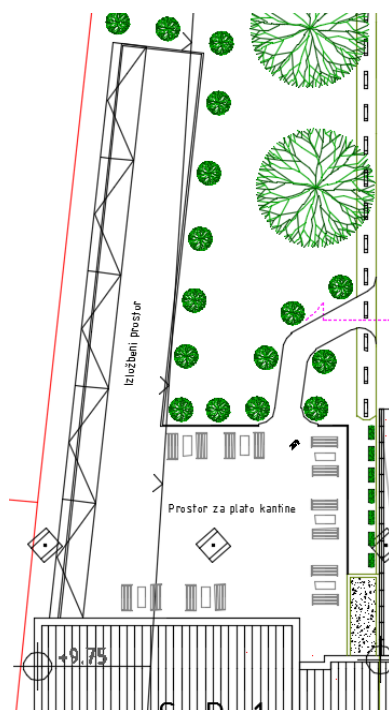

Slika 7 - Dodatni sadržaji u okviru aneksa
Figure 7 - Additional content within the annex

4. LANDSCAPING

The treatment of green areas within the lot was approached with an aim to improve the current state of the pedestrian lane that connects the building of the Faculty with the Dudova šuma, but also to create conditions of proper exploitation of the large green area. Below are six different types of landscaping. On the green surfaces and around the pedestrian lanes it was anticipated to plant seedlings of Catalpa. Catalpas are fast-growing seedlings, ball-shaped, with maximum height of up to 15.00 m which provide good shade, moreover, their scent repels various insects, such as mosquitoes, which makes them practically ideal seedlings for parks. In addition, in front of the building itself, on the left side of the entrance, in all variants, there are benches and tables for rest, as well as a parking space for bicycles.

Option I

The solution (Figure 2) consists of a circle of 30.00 m in diameter, located at the centre of this solution, where the pedestrian lanes of width 1.60 m flow in. This solution virtually looks like a roundabout. The pedestrian lanes are connected to the entrance to the lot, with a pedestrian lane in front of the Faculty building, with a path behind the faculty, with parking area in front of and behind the Faculty building and with the Morus Wood. The central circle shall contain benches and summer garden of 5,00 m in diameter, to serve as the rest area for students and visitors of the Faculty, as well as for performing extracurricular activities. Also, installation of park lighting of 4.00 m in height is envisaged.

Option II

The idea for this solution originated from the emblem of the Faculty of Civil

4. OBRADA ZELENIH POVRŠINA

Obradi zelenih površina u okviru parcele se pristupilo sa željom poboljšanja trenutnog stanja pešačke staze koja spaja zgradu fakulteta sa Dudovom šumom, ali i iz uslova pravilnog iskorišćenja velike zelene površine. U nastavku je predstavljeno šest različitih obrada zelene površine.

Na zelenim površinama i oko pešačkih staza su predviđene sadnice drveta katalpa. Katalpe su brzorastuće sadnice, loptastog oblika, maksimalne visine do 15,00 m koje pružaju dobar hlad, ali isto tako njihov miris odbija razne insekte, kao što su komarci, te su praktično idealne sadnice za parkove. Dodatno su ispred same zgrade fakulteta, sa leve strane ulaza, u svim varijantama, predviđene klupe i stolovi za odmor, kao i parking prostor za bicikle.

Varijanta I

Rešenje (Slika 2) se sastoji iz kruga prečnika 30,00 m, koji se nalazi u centru ovog rešenja, i u koji se ulivaju pešačke staze širine 1,60 m. Ovo rešenje praktično ima izgled kružnog toka. Pešačke staze su spojene sa ulazom na parcelu, sa pešačkom stazom ispred zgrade fakulteta, sa stazom iza fakulteta, sa parkingom ispred i iza zgrade fakulteta i sa Dudovom šumom. Na centralnom krugu je predviđeno postavljanje klupa i letnjikovca prečnika 5,00 m, za odmor studenata i posetilaca fakulteta, kao i za obavljanja vannastavnih aktivnosti. Takođe, predviđeno je i postavljanje parkovske rasvete visine 4,00 m.

Varijanta II

Ideja za ovo rešenje je proizašla iz amblema Građevinskog fakulteta Subotica. Glavna pešačka staza prolazi kroz centar stilizovanog amblema, a dalje se razdvaja na staze prema ulazu u parcelu, prema pešačkoj stazi ispred,

Engineering in Subotica. The main pedestrian lane passes through the centre of the stylized emblem, and then splits to lanes towards the entrance to the lot, towards the lane in front, as well as behind the Faculty building and towards the Morus Wood. (Figure 8). Solution anticipates placing benches for rest in the circular area of stylized emblem for students and visitors of the Faculty, as well as park lighting with height of 4.0 m. By carrying out this solution, the Faculty would gain its distinguished “stamp”.

kao i iza fakulteta, i prema Dudovoj šumi (Slika 8). Rešenjem je predviđeno postavljanje klupa za odmor u kružnom delu stilizovanog amblema za studente i za posetioce fakulteta, kao i parkovska rasveta visine 4,00 m. Izgradnjom ovog rešenja, fakultet dobija svoj prepoznatljiv „pečat”

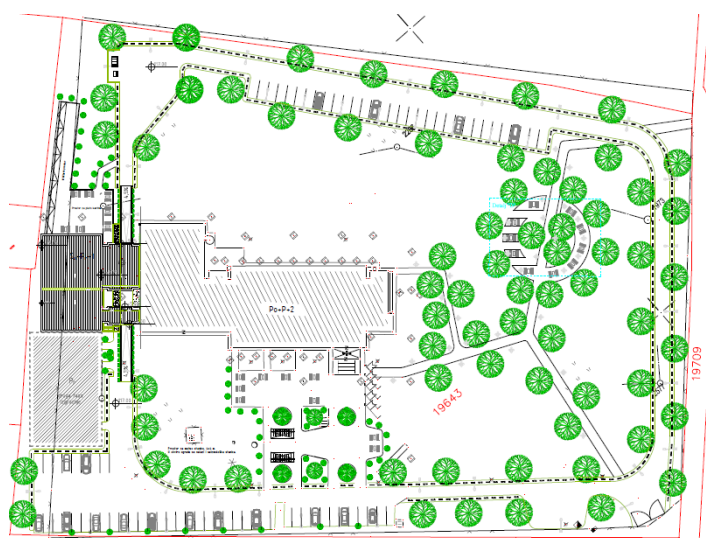

Slika 8 - Uređenje zelenih površina, varijanta II
Figure 8 - Landscaping, option II

Option III

The idea for the solution originates from landscaping of typical parks, but also from the landscaping the Dudova šuma itself. Solution follows winding pedestrian lanes, as well as benches and summer houses placed by random order (Figure 9). Pedestrian lanes connect entrance to the lot, lanes in front of and behind the Faculty building, with parking area alongside the new traffic route, as well as with Dudova šuma. Also, installation of park lighting of 4.00 m in height is envisaged.

Varijanta III

Ideja rešenja proizilazi iz uređenja tipičnih parkova, ali i samog uređenja parka u Dudovoj šumi. Rešenje prate krivudave pešačke staze, kao i klupe i letnjikovci postavljeni po nasumičnom rasporedu (Slika 9). Pešačke staze spajaju ulaz na parcelu, staze ispred i iza fakulteta, sa parkingom uz novu saobraćajnicu, kao i sa Dudovom šumom. Takođe, predviđena je i parkovska rasveta visine 4,00 m.

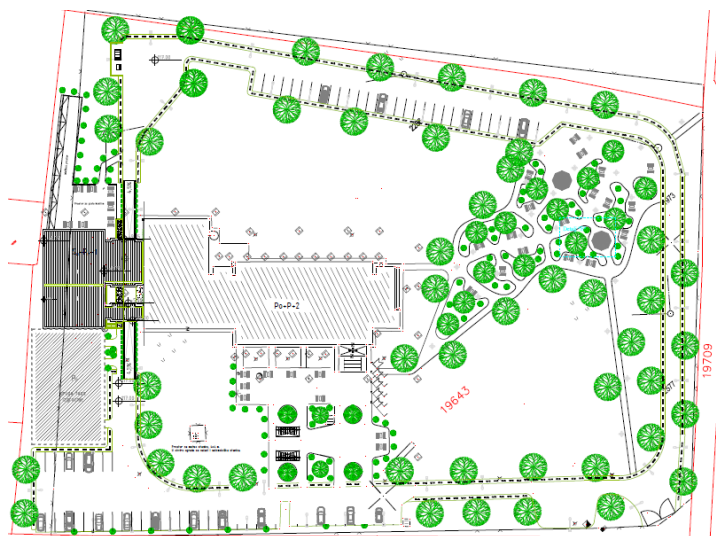

Slika 9 - Uređenje zelenih površina, varijanta III
Figure 9 - Landscaping, option III

Option IV

This solution anticipates forming the pedestrian lanes as refuges, with diameter of 14.00 m (Figure 10). Three refuges were designed in total. Each refuge contains one summerhouse with diameter of 5.00 m with benches inside and around the summerhouse.

Pedestrian lane connects entrance to the lot, lane in front of and behind the Faculty building, parking area alongside the new traffic route, as well as the Dudova šuma. The solution is also supported by the park lighting of 4.00 m in height.

Option V

Similar to the variant IV, this solution consists of three refuges with diameter 14.00 m, interconnected, with two summerhouses in each refuge, as well as with benches intended for resting (Figure 11). Pedestrian lanes connect entrance to the lot, lane in front of and behind the Faculty building, parking area alongside the new traffic route, as well as the Dudova šuma. The solution

Varijanta IV

Ovim rešenjem je predviđeno formiranje pešačkih staza kao ostrva, prečnika 14,00 m (Slika 10). Ukupno su projektovana tri ostrva. Na svakom se nalazi po jedan letnjikovac prečnika 5,00 m sa klupama unutar i oko letnjikovca. Stazom je povezan ulaz na parcelu, staza ispred i iza fakulteta, parking uz novu saobraćajnicu, kao i Dudova šuma. Rešenje prati i parkovska rasveta visine 4,00 m.

Varijanta V

Slično kao i varijanta IV, ovo rešenje se sastoji od tri ostrva, prečnika 14,00 m, međusobno povezana, sa po dva letnjikovca unutar svakog, kao i sa klupama za odmor (Slika 11). Pešačkim stazama su spojeni ulaz na parcelu, staza ispred i iza fakulteta, parking uz novu saobraćajnicu, kao i Dudova šuma. Rešenje prati i parkovska rasveta visine 4,00 m.

is also supported by the park lighting of 4.00 m in height

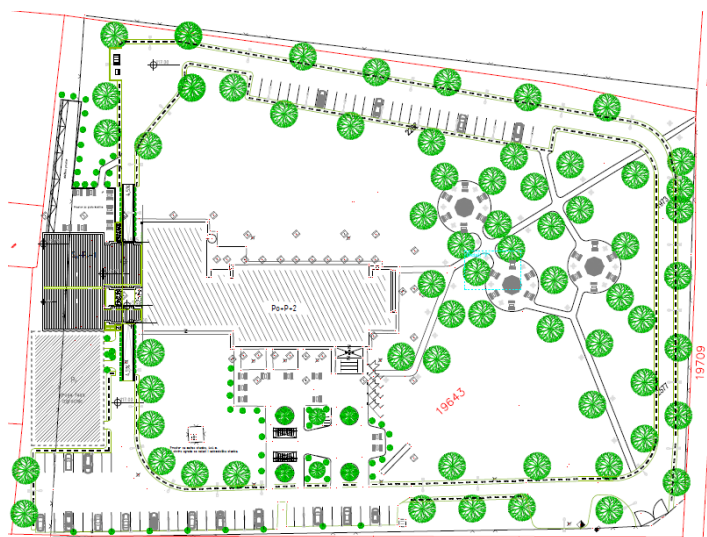

Slika 10 - Uređenje zelenih površina, varijanta IV
Figure 10 - Landscaping, option IV

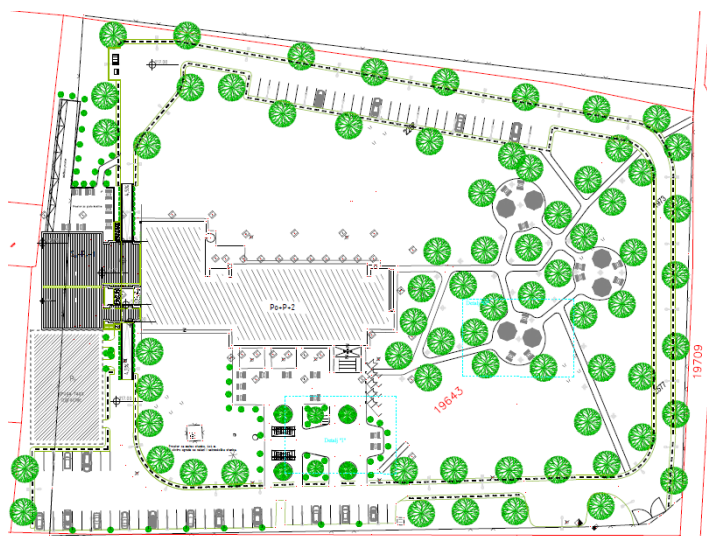

Slika 11 - Uređenje zelenih površina, varijanta V
Figure 11 - Landscaping, option V

Option VI

The existing landscape of Aleja Maršala Tita in Subotica served as the basis for this solution. The alley is one of the most famous streets in Subotica, about 850 m long. It is characterized by a wide pedestrian lane located in the middle, with both sides surrounded by the traffic lanes. The solution (Figure 12) includes three summer houses on each side, followed by resting benches, as well as the tree line of Catalpas in the middle of the pedestrian lane, whose width is 25,00 m. Pedestrian lane connects entrance to the lot, lane in front of and behind the Faculty building, parking area alongside the new traffic route, as well as the Dudova šuma. The solution is also supported by the park lighting of 4.00 m in height.

Varijanta VI

Postojeće uređenje Aleje Maršala Tita u Subotici je poslužilo kao osnova ovog rešenja. Aleja je jedna od najpoznatijih ulica u Subotici, dužine oko 850 m. Karakteristična je po širokoj pešačkoj stazi koja se nalazi na sredini, obostrano ograničenoj saobraćajnim trakama. Na rešenju (Slika 12) se nalaze po tri letnjikovca sa obe strane, praćene klupama za odmor, kao i drvodred katalpi na sredini pešačke staze, širine 25,00 m. Pešačkom stazom su spojeni ulaz na parcelu, staza ispred i iza fakulteta, parking uz novu saobraćajnicu i Dudova šuma. Rešenje prati i parkovska rasveta visine 4,00 m.



Slika 12 - Uređenje zelenih površina, varijanta VI
Figure 12 - Landscaping, option VI

5. INVESTMENT VALUE

The investment value includes the costs of reconstruction of the existing traffic surfaces, building new ones, and landscaping. Earthworks, sewerage, concrete works, finishing of surfaces

5. INVESTICIONA VREDNOST

Investiciona vrednost obuhvata troškove rekonstrukcije postojećih saobraćajnih površina, izgradnju novih, te uređenje zelenih površina. Obuhvaćeni su zemljani, kanalizacioni,

and landscaping are included. The value of the works is shown in Table 1, individually by variants, including also the unforeseen costs in the amount of 3%.

betonski radovi, završne obrade površina i uređenje zelenih površina. Vrednost radova je prikazana u Tabeli 1, i to pojedinačno po varijantama, pri čemu su obuhvaćeni i nepredviđeni troškovi u iznosu od 3%.

Tabela 1 - Investiciona vrednost
Table 1 - Investment value

varijanta option	vrednost [RSD] value [RSD]	vrednost [EUR] value [EUR]
I	25.223.074,04	205.065,64
II	22.966.675,70	186.720,94
III	24.733.034,03	201.081,58
IV	23.635.012,83	192.154,58
V	24.821.888,01	201.803,97
VI	25.733.664,61	209.216,79

6. CONCLUSION

Any idea of expanding the capacity of the facility leads to an increase in demand, and this is most frequently the area for moving and resting vehicles, and surfaces for rest. It is therefore important to consider all the needs of the building and ideas to develop at the appropriate level.

In the specific case, a solution was developed for the processing of traffic surfaces on the lot of the Faculty of Civil Engineering in Subotica in support of the expansion of the existing building, and significant increase in the parking capacity was achieved, and the lot was fully serviced by surfaces for the movement of vehicles and pedestrians, with additional elaboration of contents.

6. ZAKLJUČAK

Svaka ideja o proširenju kapaciteta objekta dovodi do povećanja potražnje i to najčešće površina za kretanje i mirovanje vozila, i površina za odmor. Samim tim je značajno sagledati sve potrebe objekta i ideje razraditi na odgovarajućem nivou.

U konkretnom slučaju je razrađeno rešenje obrade saobraćajnih površina na parceli Građevinskog fakulteta u Subotici kao podrška proširenju postojećeg objekta, te ostvareno značajno povećanje kapaciteta parkiranja, a parcela je u potpunosti servisirana površinama za kretanje vozila i pešaka, uz dodatnu razradu sadržaja.

REFERENCES

- [1] Maletin, M., *Planiranje i projektovanje saobraćajnica u gradovima* (Planning and Design of Traffic Infrastructure in Cities), Orion art, Beograd, **2009**.
- [2] Maletin, M., Anđus, V., Katanić, J., *Tehnička uputstva za projektovanje lokalne gradske putne mreže (PGS-LM/08)* (Technical Guidelines for Design of Local City Transportation Network (PGS-LM/08)), Građevinski centar, Beograd, **2010**.
- [3] Maletin, M., Anđus, V., Katanić, J., *Tehnička uputstva za projektovanje parkirališta (PGS-P/08)* (Technical Guidelines for Design of Parking Areas (PGS-P/08)), Građevinski centar, Beograd, **2010**.